

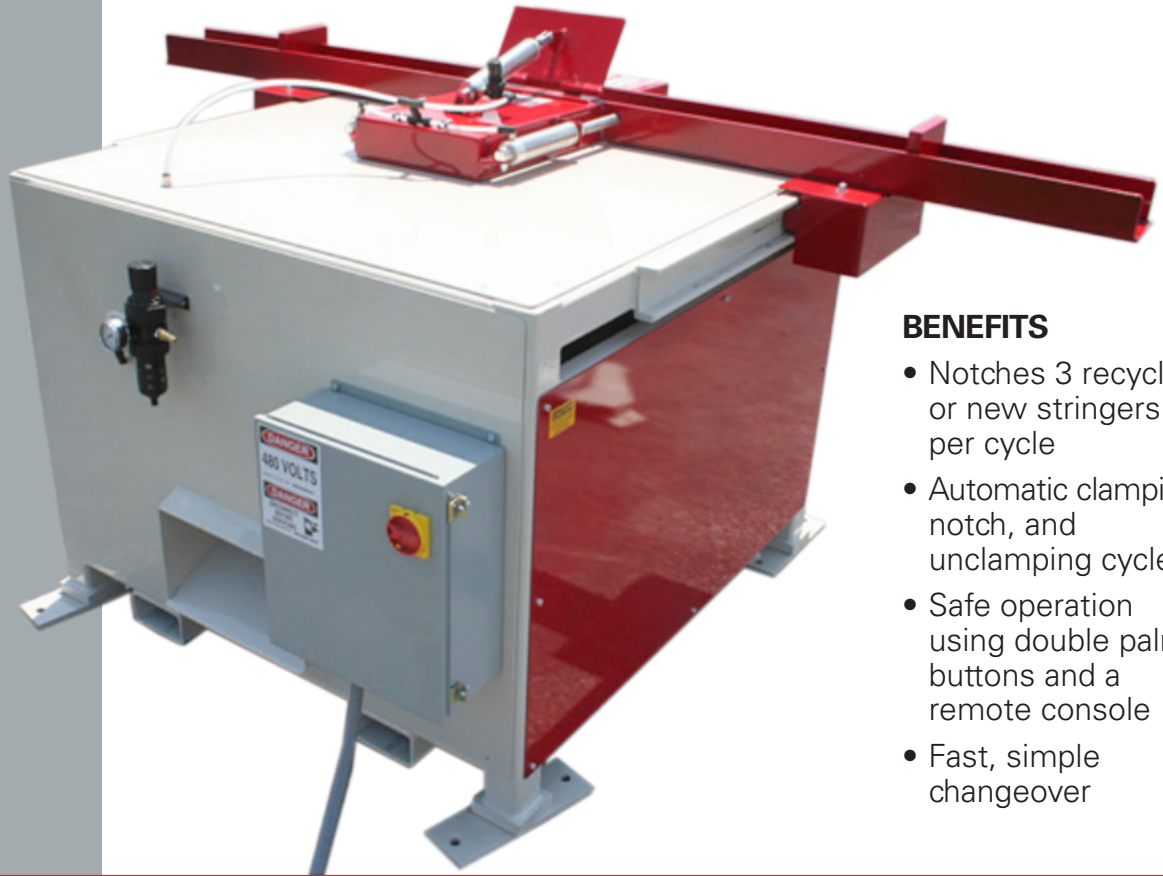

BUILT-WELL SINGLE HEAD NOTCHER



BENEFITS

- Notches 3 recycled or new stringers per cycle
- Automatic clamping, notch, and unclamping cycles
- Safe operation using double palm buttons and a remote console
- Fast, simple changeover



20 hp recommended for recycled stringers



We know that the single head notcher is central to any pallet operation. Our BUILT-WELL Single Head Notchers were designed to be productive, safe, and dependable. These versatile machines notch 3 stringers at once and change over quickly to an infinite amount of different configurations. Plus, the operator is kept out of harms way with advanced guarding, stringer clamping, and a remote double palm button control system.

Our BUILT-WELL Single Head Notcher comes equipped with pneumatically actuated clamping and carriage functions, 3 phase electrical (prewired to your voltage requirement), and an air filter and regulator.



PRS GROUP INC.
2 Eastgate Drive Jacksonville, IL 62650

www.prsgroupinc.com
217-291-0009



BUILT-WELL SINGLE HEAD NOTCHER

SPECIFICATIONS	
Motor <i>S15 Model</i>	15 HP (11.1855 KW)
Motor <i>S20 Model</i>	20 HP (14.914 KW)
Drive System	Belt Driven, Triple V
Controller	PLC, Double Palm Button Safety – On remote pedestal
Pneumatics Required	Yes
Cutter Head	Indexable, 9" Long, 1" Radius – Carbide or Nail Resistant Carbide
Material Capacity	Up to 4.75" (0.12065 m) wide

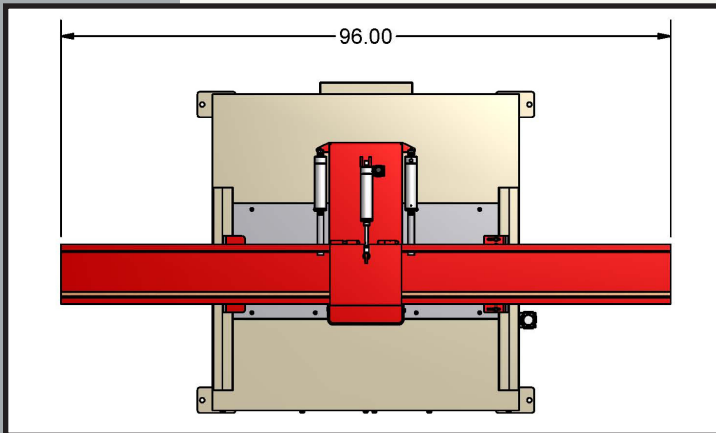

Remote console with double palm controls

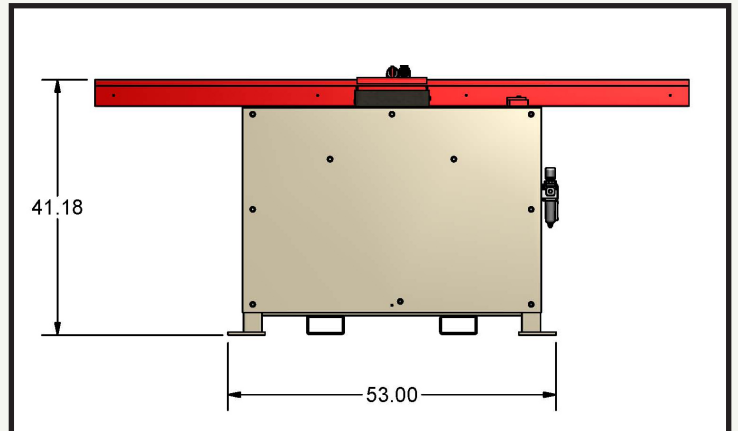
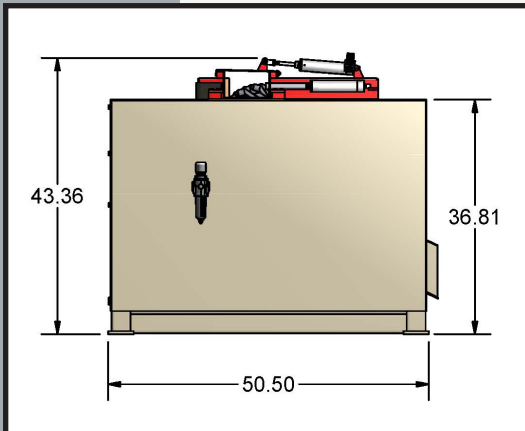

PRSGROUP INC.
2 Eastgate Drive Jacksonville, IL 62650

www.prsgroupinc.com
217-291-0009